



DNV 118 BBL LIQUID TIGHT ROLL-OFF VACUUM CUTTINGS CONTAINER

▶ COMMON USES

Used for transportation and storage of cargo or liquid type sludge, cuttings and waste. Meets DOT packaging requirements for Packing Group 3 combustible materials 49 CFR 173.241. Designed for standard hoist or roll off trailers. The CSC plating allows for shipping throughout multiple regions utilizing standard transportation modes (i.e. container ship, rail, or truck). Products can be shipped directly to or from an offshore drilling/production operation and then get transported by a roll-off trailer or intermodal carrier without being classified as out of gauge/break bulk or being repackaged. This drastically reduces the cost of supporting oilfield operations in distant or remote locations.

▶ TECHNICAL DATA

DIMENSIONS	L X W X H	
EXTERNAL (MM)	6096 x 2438 x 2591	
EXTERNAL (FT)	20' x 8' x 8'6"	
INTERNAL (MM)	5694 x 2102 x 1765	
INTERNAL (FT)	18'8" x 6'10" x 5'9"	
WEIGHT	KGS	LBS
TARE	6900	15215
PAYLOAD	17700	39025
MAX GROSS WEIGHT (MGW)	24600	54240
VOLUME	CU M	GAL
INSIDE CAPACITY	18.77	4967
ADDITIONAL FEATURES		
<ul style="list-style-type: none"> • Designed, Constructed, Tested to EN12079-1 / DNV 2.7-3 / SEPCo OPS 0055 / API RP 		



▶ DRAWINGS

FRONT VIEW

2438 mm [96"] [8']

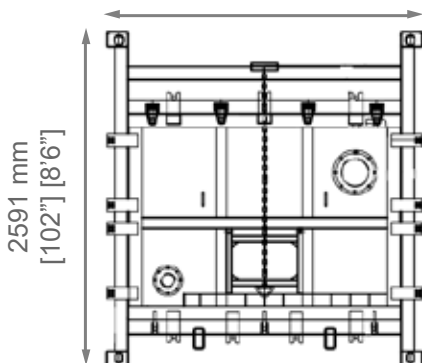

SIDE VIEW

6096 mm [240"] [20']

