

Insulated & Non-Insulated Grocery Boxes



COMMON USES: *Insulated for food and other perishable items while in storage and transportation. Non-Insulated for all other non-perishable sealed items.*

SPECIFICATIONS

- Designed for offshore dynamic lifting in accordance with the provisions of API RP 2A and SEPco document OPS0055
- Est. Tare Weight: 6,300 LBS. [2,858 KG]
- Max Gross Weight: 15,000 LBS. [6,804 KG]
- Pay Load Weight: 8,700 LBS. [3,946 KG]
- Heavy duty 1/4" steel construction
- Three inch thick insulation around
- Completely galvanized
- Full open reefer style door
- Three heavy duty hinges with grease zerks
- External dimensions:
 - Length: 1,829 mm [72"] [6']
 - Width: 2,540 mm [100"] [8'-4"]
 - Height: 2,134 mm [84"] [7']
- Internal dimensions:
 - Length: 1,626 mm [64"] [5'4"]
 - Width: 1,829 mm [72"] [6']

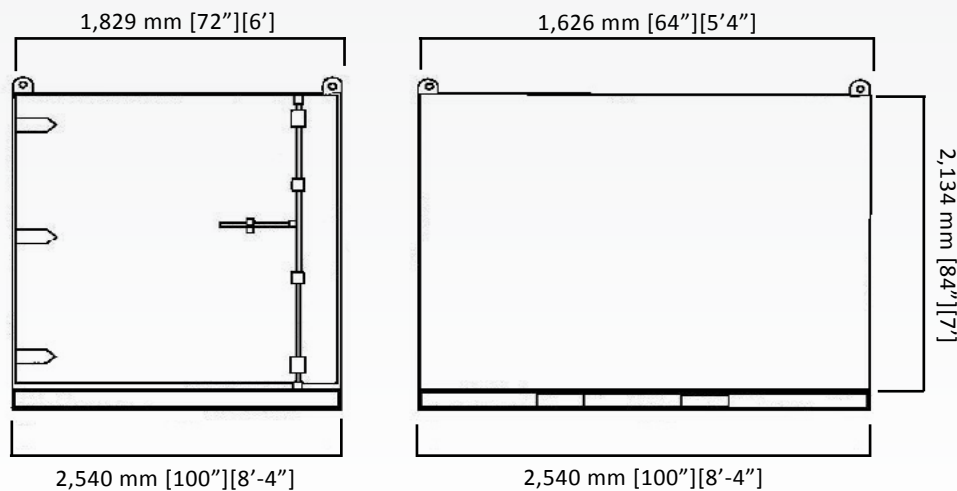

Make it happen.

www.TigerOffshoreRentals.com | 24/7 Dispatch 1.877.844.3791