

100 BBL USCG Approved Marine Portable Tank (MPT)



COMMON USES: This all purpose 100 BBL MPT fluid tank can be used for produced water processing, pipe-line flushing tankage, waste oil collection, drilling mud transfer and much much more.

SPECIFICATIONS

- 20 inch manway, 3 inch male camlock with cap, pressure and vacuum relief vent flow rate of 4208 cubic feet of free air per minute as required by CFR 49, 178.270-11.
- Set at 25 PSI/6 in vacuum.
- Designed for offshore dynamic lifting in accordance with the provisions of API RP 2A.
- Built in ladder
- Four point lifting arrangement
- Exterior coatings, zinc rich epoxy primer, polyurethane top coat
- Interior coatings, high-build epoxy lining system
- External Dimensions:
 - Length: 4,343 mm [171"] [14'3"]
 - Width: 2,438 mm [96"] [8']
 - Height: 3,150 mm [124"] [10'4"]
- M.A.W.P. (PSIG): 26
- Test Pressure (PSIG): 39
- External Pressure (PSIG): 7.5
- Total Capacity (Gallons): 4,200
- Est. Tare Weight: 9,520 lbs [4,318 KG]
- Max Gross Weight: 55,000 lbs [24,948 KG]
- Pay Load Weight: 45,480 lbs. [20,629 KG]

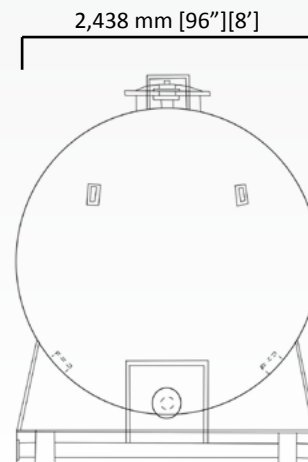
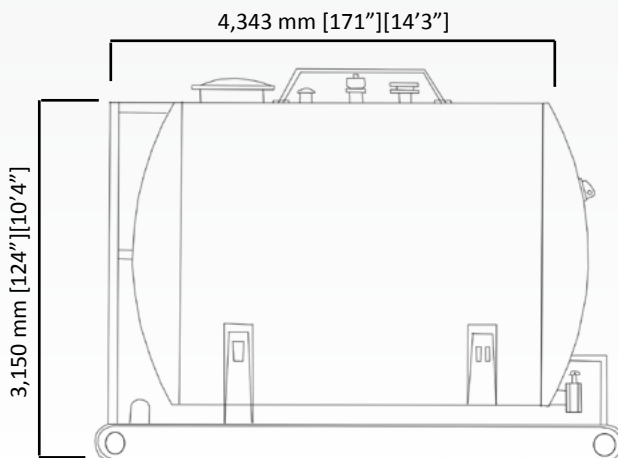

Make it happen.

www.TigerOffshoreRentals.com | 24/7 Dispatch 1.877.844.3791